

THIS DOCUMENT AND ALL INFORMATION THEREIN CONTAINED ARE OUR EXCLUSNE PROPERTY.THE RECIPIENT AGREES NOT TO REPRODUCE COPY,USE OR TRANSMIT THIS DOEUMENT AND\OR THE INFORMATION THEREIN CONTAINED FOR ANY PURPOSE.EXCEPT WITH OUR WRITTEN PERMISSION

DRAWING CREATED ISO STANDARDS

FUER DIESE ZEICHUNG BEHALTEN WIR UNS ALLE RECHTE NACH DIN 34 FOR

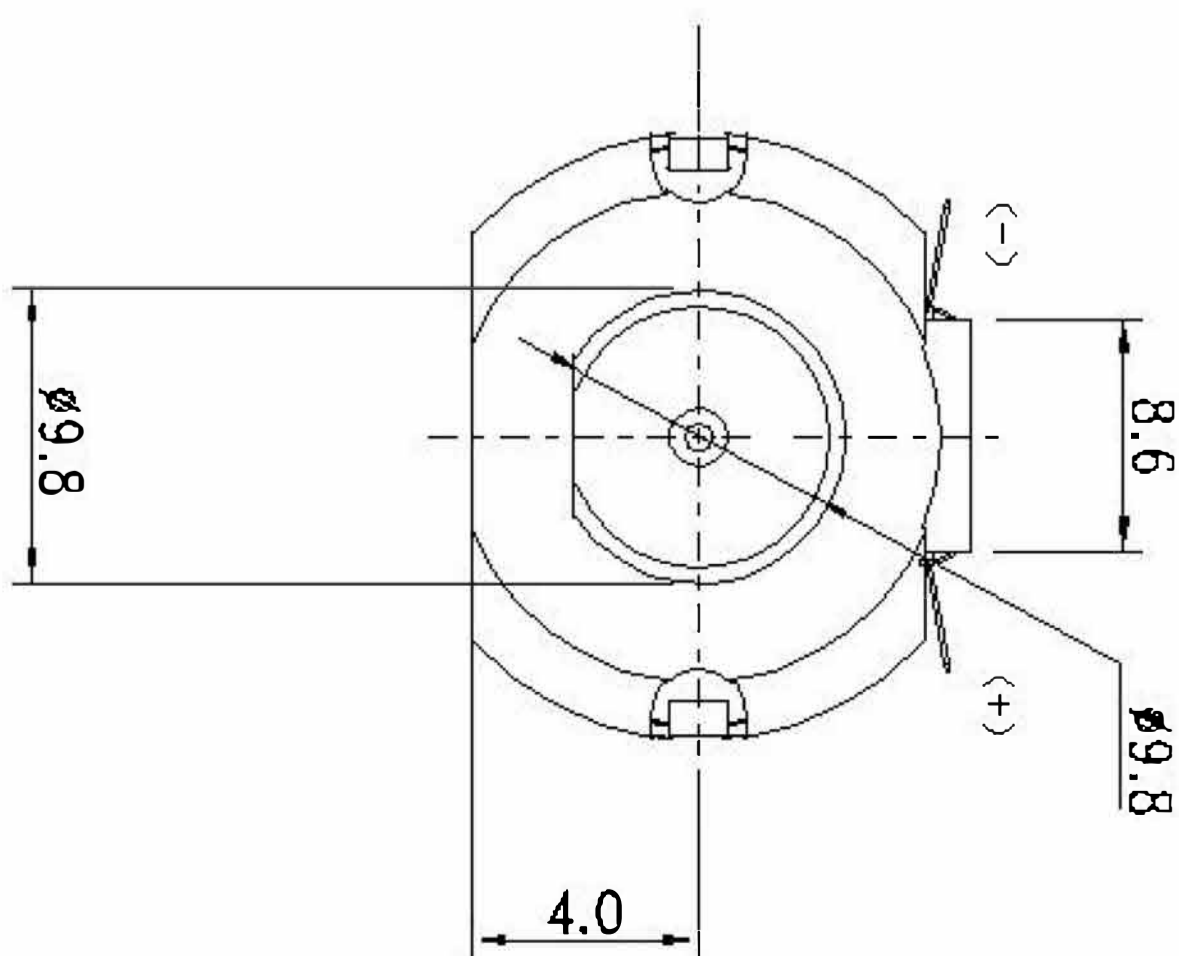
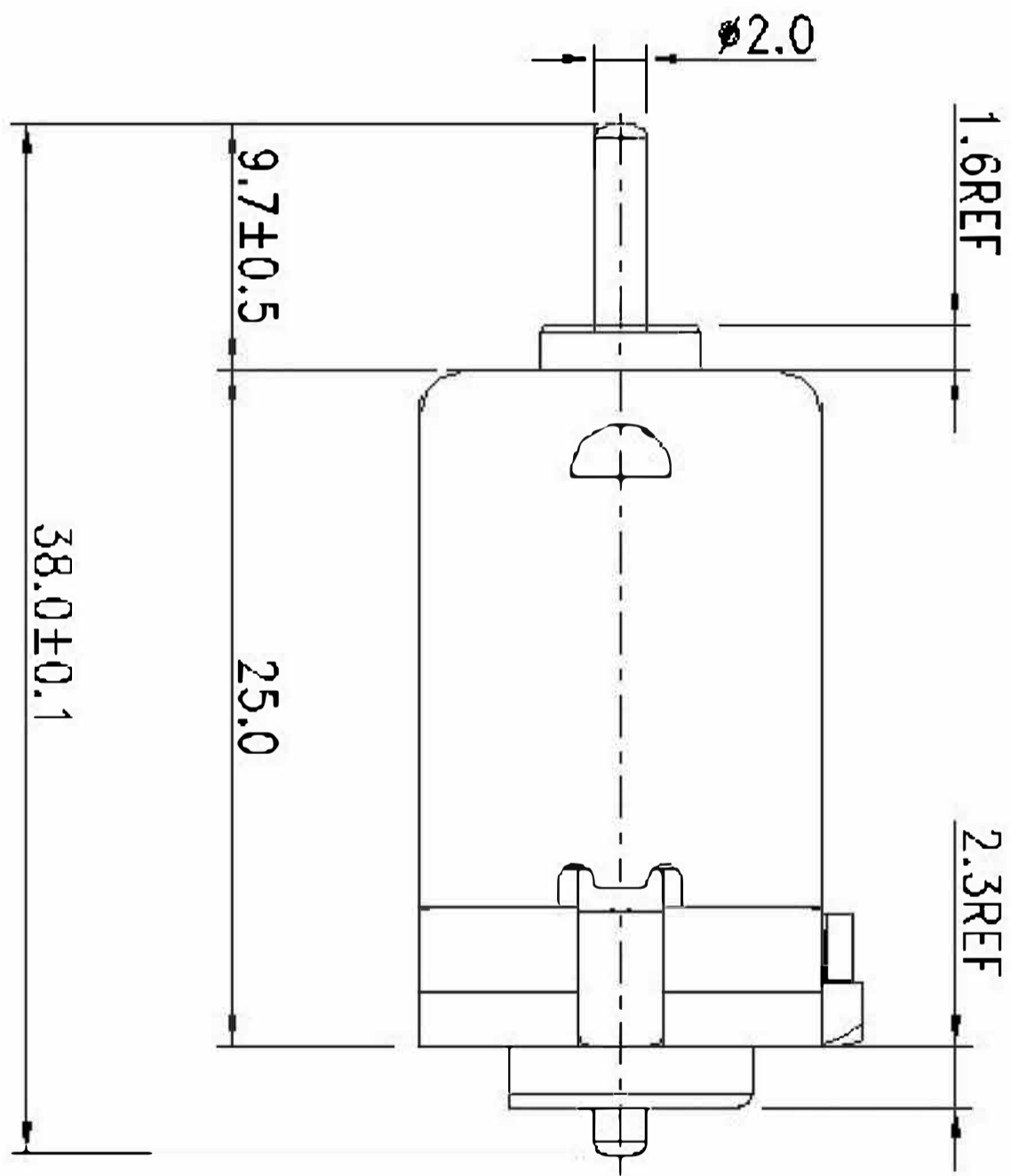
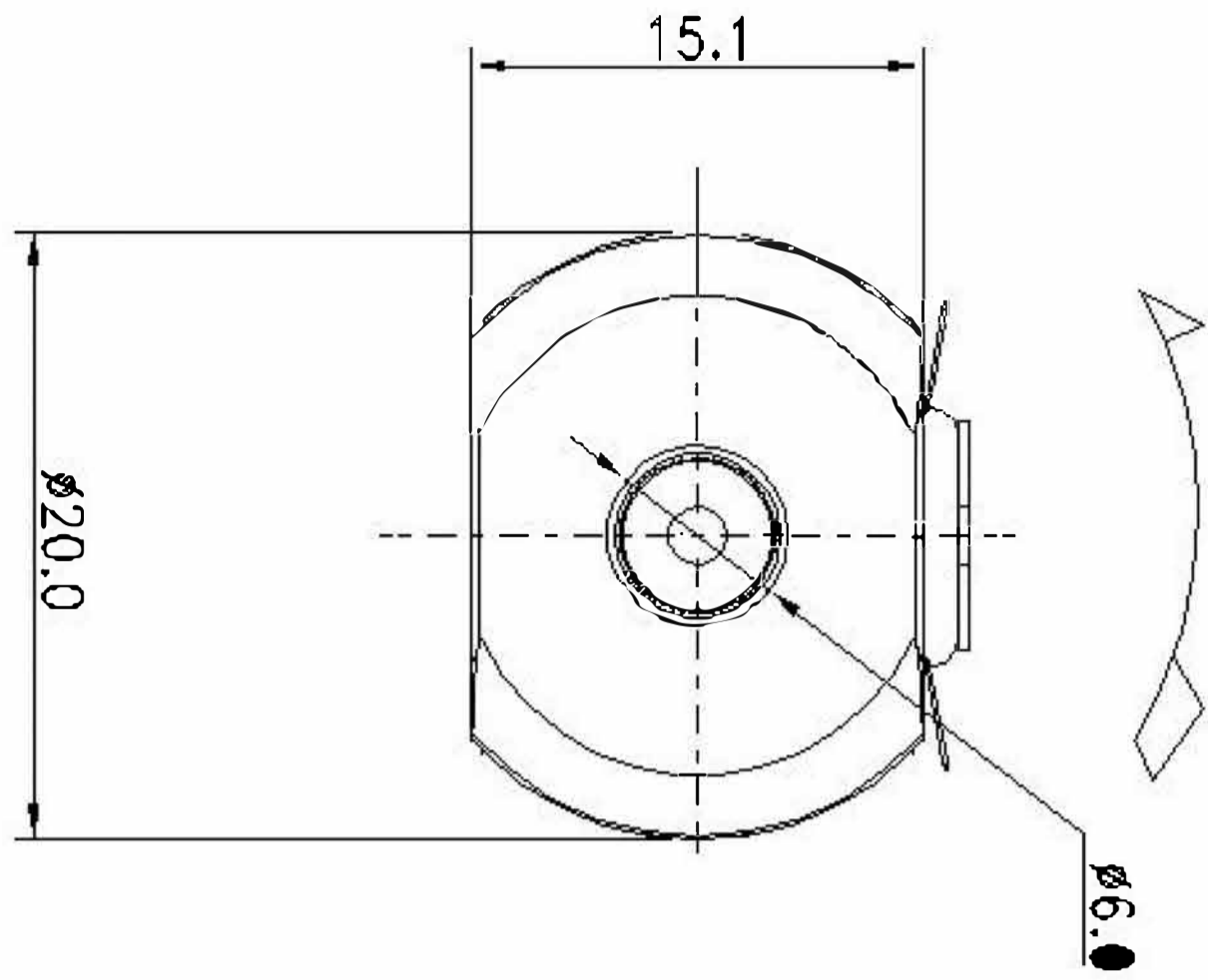

未注公差		圆角半径和倒角高度			
0~6	6~30	30~120	0~3	3~6	6~30
±0.06	±0.1	±0.2	±0.2	±0.5	±0.8



TITLE:	外形图
MATERIAL:	RE130-2270-38
DRAWING NO:	

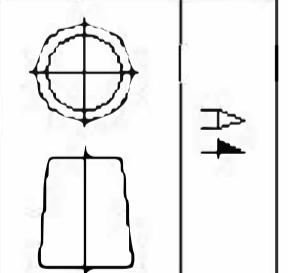

DRAWER:	
CHECKER:	
APPROVER:	

DO NOT SCALE THE DRAWING

1 2 3 4 5 6

A B C D

A B C D

MOTOR OUTGOING SPECIFICATION

Model No. : 130-2270-38

Sample No. :

- | | |
|---|---|
| 1.Motor Type:
马达类型 | Small PMDC motor
微型直流马达 |
| 2.Standard Operating Conditions:
标准工作条件 | |
| 2-1 Rated Voltage(额定电压): | 3.0V DC CONSTANT between motor terminals(端子电压3.0V) |
| 2-1 Direction of Rotation(旋转方向): | CCW, when viewed from output shaft side(从输出轴端看CCW) |
| 3.Electrical Characteristics(at initial stage after 30 seconds run-in):
电气特性(启动30秒后初始阶段) | |
| 3-1 No Load Current(空载电流): | 0.4A max |
| 3-2 No Load Speed(空载转速): | 16000±10%rpm |
| 3-3 Rated Load(tested with fan mm):
额定负载(mm风叶) | 11.9g.cm |
| 3-4 Rated Current(额定电流): | 1.5A max |
| 3-5 Rated Speed(额定转速): | 12400±8%rpm |
| 3-6 Noise(噪音): | 30cm≤68dB |
| 3-7 Motor Characteristic Curve(马达特性曲线): | See Motor Performance Curves And Characteristics(看马达特性曲线图). |
| 4.Mechanical Characteristics:
机械特性 | |
| 4-1 External Appearance(外形): | See Outline(看外形图) |
| 4-2 End Play(端位): | 0.05~0.45mm |
| 4-3 Runout of Shaft Extension(轴突端跳动): | 0.02mm max |

CONFIRMED & ACCEPTED BY CUSTOMER (客户接受&确认)

COMPANY,CHOP & SIGNATURE (盖章&签名)

PREPARED: _____ CHECKED: _____ APPROVED: _____